

COLORADO DEPARTMENT OF TRANSPORTATION STAFF BRIDGE BRIDGE DETAIL MANUAL	Chapter: 02 Effective: November 17, 2022 Supersedes: March 19, 2019
DRAFTING STANDARDS AND PROCEDURES	

2.1 DRAWING LAYOUT

Before beginning either a hand-drawn or an electronic drawing, the detailer should carefully study the object to be detailed to determine the necessary views and sections, as well as a scale, or scales for illustration, which will leave sufficient space on the drawing for dimensions and notes. More than one sheet may be required to depict some objects sufficiently. Drawings done previously of similar objects are a valuable resource.

For structural drawings, the preference is to use a 1" = 1' border with scaled references of the original linework that is drawn true scale.

Third angle Orthographic Projection (i.e. Plan, Elevation, and Section) is the preferred system for displaying structural details. Use as many views as needed to fully define the object. Perspective views, axonometric (3D) views and photographs may be used to illustrate or clarify a complex detail, but should not be used in lieu of the usual orthographic views.

All details throughout the plans shall be oriented consistently, with all views looking ahead station, except that Abutment 1 shall be drawn looking back station. Views used in the drawings will usually consist of a top view, a front view, and a right side view or section. Additional sections may be used to clarify the object and shall be cross referenced. The detailer should attempt to produce a drawing without the views being crowded or placed haphazardly on the drawing. By the same token, an enlarged scale for illustration should not be used solely to fill up a sheet.

When drawing an elevation view below the related plan view, the plan view should be oriented so as to be normal to the elevation view to aid in orthographic projection. Typical examples of this are seen in abutment, pier and wall sheets.

Avoid crossing dimension lines, leaders, and overlapping items to make plans legible.

2.2 CONFIGURATION FILES

Hand-drawn drawings are created by following the guidelines presented in this chapter and the detailer's expertise. Electronic standards to mimic the hand drawn requirements are provided by CDOT to simplify the process of creating electronic drawings. Configuration files include standard text styles, dimension styles, levels/layers and plot settings. The configuration files are available for Consultants' use at <https://www.codot.gov/business/designsupport/cadd> . The goal of these files is to provide default settings which mimic standard practice. With a consistent electronic format, changes to the drawing or plotting can be accomplished easily by anyone, not just the original detailer. Consistent print format is important because it creates a consistent finished product. If changes or additions to the configuration files are required, please contact the CDOT Bridge Users Group.

2.3 SCALES

In hand-drawn drawings it is critical that the detailer determine the proper scale and layout as described in Section 2.1 to avoid major changes or corrections. In electronic files, much of the linework can be generated in a “model” before determining the final drawing scale. All linework for details should be drawn true size where one drawing unit is equal to one foot, with the plan views of General Layouts drawn at the correct project coordinates if available. For projects where project coordinates are not used or needed, see Inspection Sketch. Once drawn correctly in the model, the referenced linework can be rotated and scaled in the drawing border without affecting the original linework.

Scales for illustrating views should be large enough to show the required details clearly on a finished 11 x 17 inch sheet (ANSI B size). Larger scales should be used for sections, so that reinforcing and other details are clear.

Standard architectural or civil scales are necessary to hand-draw a drawing and should be also used for referencing the linework to the finished drawing border in electronic drawings. This facilitates the creation of field drawn “as-built” plans and changes. Just fitting the detail to the drawing at no particular scale is not recommended unless dictated by time or space requirements. When all details or sections on a drawing layout are at the same scale, the scale information block on the border should be filled in or edited with the correct scale. If varying scales are used on the drawing, the scale information block on the border should be filled out with VARIES, NOT TO SCALE, NTS, NONE or other appropriate description.

Suggested scales are 1" = 30', 1" = 40', 1" = 50', 1" = 60' for general layout drawing. Sections and details will generally be at larger scales and will follow architectural scales, e.g. 1/2"=1'-0", 1/8" = 1'-0", etc..

Note: Distances, offsets, text heights, etc. given in this chapter refer to drawings on an 11 x 17 inch sheet.

2.4 STRENGTH AND CONTRAST OF LINES

The lineweight and visibility of lines can be precisely controlled either by hand or electronically. Varying the width of lines between different line types increases the clarity and ease of reading the drawings. Each linetype on a drawing has a definite meaning and is drawn in a certain way. The contrast between the different widths of lines should be distinct. Line types used include, but are not limited to the lines depicted in Figure 2.4-1.

In hand drawing methods, linetypes and weight are controlled by the detailer and his/her choice of the size of the pen or pencil. Although several methods are available in software generated drawings, linetypes and weight are preferred to be controlled by the level/layer upon which items are drawn. The printing configuration file will then determine the "look" of the hardcopy. The line widths shown below approximate the hand drawn widths and are intended to be the basis for printing configuration files. The use of grayed out linestyles on the final hardcopy may be used by the detailer to increase the readability of the drawings.













<u>Linetype</u>	<u>Width</u>	<u>Description/Use</u>
	0.012"	Visible Object Line or Profile Line - Used as the Visible Outline of the objects, should be an outstanding feature and consists of a continuous unbroken line
	0.008"	Hidden - Used to indicate hidden or invisible object lines and consists of evenly spaced short dashes
	0.004"	Centerline - Indicates a centerline of an object or objects and consists of long and short dashes, alternately spaced
	0.008"	Dashed - Used to indicate existing object lines and consists of evenly spaced medium length dashes
	0.006"	Dimensions and Extension Lines - Used to dimension an object and consists of unbroken lines (when possible)
	0.014"	Reinforcing Steel Line - Used to indicate reinforcing steel and consists of evenly spaced long dashes
	0.014"	Object Match Line, Section Cut Line - Identifies a Match Line or a Section Cut Line and consists of a broken line made by alternating longer dash lines with two short dash lines. Match lines are used when the details too large to be drawn, at a practical scale, in one place. Match lines should be tied in by using dimensions to some readily identifiable point on the structure or details. Each pair of match lines shall carry the same identification. For example: Match Line A or Match Line X. Current electronic files use continuous lines for section cut lines
	0.004"	Short Break Line - Used to indicate a short break in an object or a change in how it is depicted
	0.004"	Long Break Line - Used to indicate a longer break in an object
	0.016"	Survey Line or Projected Line - Indicates the Horizontal Control Line, Survey Line, Project of Projected Line. This line is continuous and should have perpendicular tick marks to indicate even stations.
	0.016"	Proposed Right of Way Line - Indicates the proposed boundary of the highway property and consists of a broken line made by alternating longer dash lines with three short dash lines
	0.010"	Existing Right of Way Line - Indicates the existing boundary of the highway property and consists of a broken line made by alternating longer dash lines with two short dash lines
	0.004"	Phantom Line - Used to show the relationship of portions of the existing structure to the new structure, as in the case of a widening or replacement structure.

Fig. 2.4-1 Hand Drawn Line Convention

Since we are using the inspection sketch linework model for multiple purposes (inspection repair, etc.) linework for existing bridges should use the continuous linetype instead of the dashed linetype (existing). Where it is necessary to show contrast between existing & proposed (widening projects), the existing portions may use the dashed linetype. The final inspection sketch linework showing the finished bridge shall use continuous linetype.

2.5 TEXT/LETTERING

The font or lettering used on the drawing should be a simple single stroke lettering as shown in Figure 2.5-1. This type of lettering is preferred to eliminate unnecessary deviations that may cause misinterpretation of a meaning or dimension. The spacing of the letters should generally be proportionate to their width. In the case of tabular data and electronic files, a non-proportionate text style may be used to line up the data. In non-proportionate text styles, each letter or number takes up the same width regardless of the letter width.

The bulk of the lettering on the drawing should be illustrated at 0.07 inches high, including dimensioning text. Text/lettering should generally be placed horizontally.

In the case of a large block of notes, as on the General Information-Summary of Quantities sheet, 0.06 inch high text may be used if absolutely necessary to fit onto the sheet. Reduced width lettering may also be used in space restricted applications. Sentence case is preferred for all notes for readability.

The "initial blocks" at the left edge of the sheets, and bar bending diagrams should use 0.05 inch high lettering. Text for titles should be all capital letters, underlined, and 1½ times the normal text height (0.105 inches).

Depending on the configuration setup, these exact text styles and heights may not be supported. If not supported, choose the closest to these recommended heights.



Fig. 2.5-1 Vertical Single Stroke Lettering

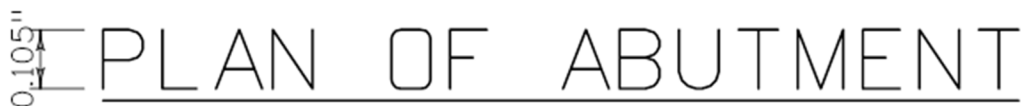

Fig. 2.5-2 Typical Example of Title

2.6 ACCURACY OF DIMENSIONS AND ELEVATIONS

The degree of accuracy used on the drawings shall be as follows:

- A) Structural dimensions to the nearest 1/8 inch with the following exceptions:
 - 1) Bearing device location dimensions on skewed abutments and piers to .001 feet.
 - 2) Stations to the nearest .01 feet.
 - 3) Layout dimensions (dimensions along tangents, etc.) to the nearest .01 feet.
 - 4) Piling location dimensions rounded to the nearest .01 feet.
 - 5) Dead load and live load deflections to the nearest .001 feet.
- B) Elevations to the nearest .01 feet with the following exceptions:
 - 1) Elevation of the top of concrete of the bearing seat to the nearest .005 feet.
 - 2) Elevations of bottom of footings, tip elevations of caissons and estimated pile tips to the nearest .1 feet.
- C) Skew angles and bearings shall match the accuracy of the roadway drawings. Angles to the nearest second are typically sufficient for construction accuracy. Example: 69°38'13" or 69°38'13.1".
- D) Other angles such that dependent dimensions meet the above criteria.
- E) Slopes given to the nearest hundredth of a percent. Example: 1.25%.

2.7 DIMENSIONING

Plans for bridges and other highway structures are a combination of Engineering and Construction drawings from which the structure is built. After the shape of an object has been described by the orthographic views, the importance of the drawing for the construction depends upon the dimensions and notes given. The dimensions shown on the drawing are not necessarily those used in making the drawing, but are those needed for the proper construction or functioning of the object. It should also be noted that not all dimensions shown on a drawing are for construction purposes, but many are given for convenient reference and checking by the Engineer. Dimensions are typically given in the format required by the construction personnel and necessary for accuracy, i.e. architectural dimensions (feet and inches) for objects constructed using tape measures including formwork and reinforcement placement, and decimal dimensions used for surveyed items including caissons and footings.

Figure 2.7-1 illustrates the typical lines or line types used for dimensioning. A complete dimension consists of extension lines, dimension line, arrowheads and dimension text or numeral and provides the information required to define an object for construction or checking. The dimension line usually bears the numeral denoting the distance and shall contrast with the object lines. The dimension line is typically drawn parallel to the object line it dimensions.

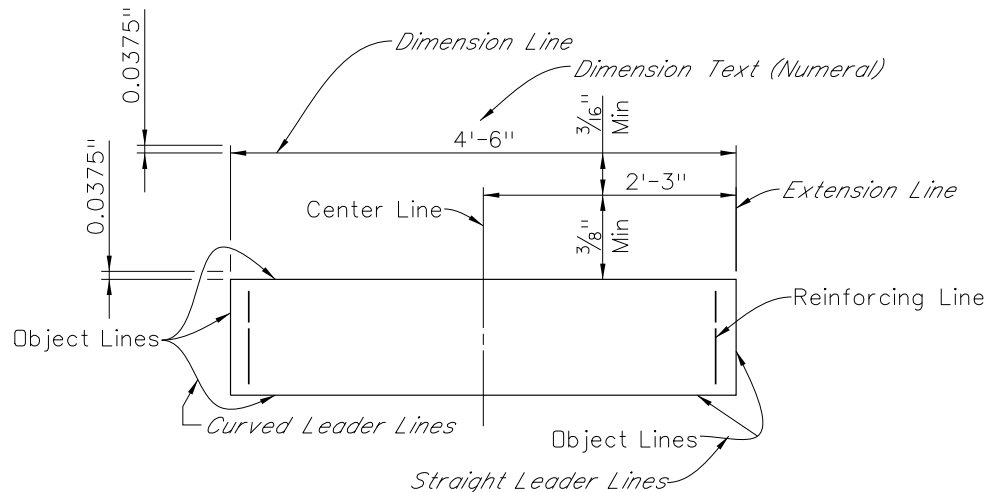

**Fig. 2.7-1 Components of Dimensioning
Object, Dimension, Extension, and Leader Lines
as Illustrated for the Printed Sheet**

The numeral is placed slightly above the line as shown in Figure 2.7-2 (a). It is permissible, if space is limited, to break the dimension line and insert the numeral as shown in Figure 2.7-2(b). In electronic files, it is not recommended to drop/explode/burst or change the text of dimensions, i.e. leave it as a dimension element. Since line work should be drawn true size, this recommendation should not cause problems. If possible, changes to the dimensions as shown in Figure 2.7-2(b) should be accomplished with the dimension style settings and not by dropping/exploding the dimension element.

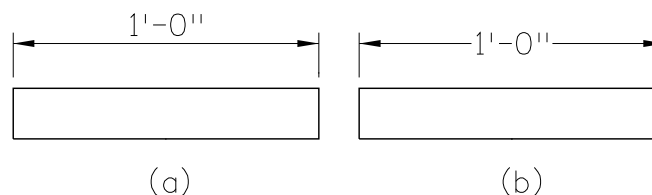

Fig. 2.7-2 Dimensions

The following statements are given as a guide for the dimensioning procedure:

- A) Required accuracy and format of dimensions are discussed in Section 2.6. Typically, dimensions are given in feet and inches format (a'-b") with an accuracy to the nearest 1/8".
- B) Dimension line spacing should be uniform throughout the drawing. The dimension lines should be at least 3/8" from the object outline. Parallel dimension lines shall be equally spaced at least 3/16" apart on the printed sheet as shown in Figure 2.7-1.
- C) Extension lines shall extend 0.0375 inches beyond the point of the arrowhead on the dimension line, and have a gap of 0.0375 inches from the object as shown in Figure 2.7-1.
- D) Directions from which the dimensions on a drawing are to be read are as follows (as depicted in Figure 2.7-3):
 - 1) The dimensions that are placed on a horizontal dimension line are to be read from the bottom of the drawing.

- 2) The numerals that are placed on a vertical dimension line are to be read from the right side of the drawing.
- 3) The numerals that are placed on an inclined line should be placed so they can be read horizontally by turning the drawing through the smallest possible angle.
- 4) All dimension numerals should be read in the direction of the dimension line.

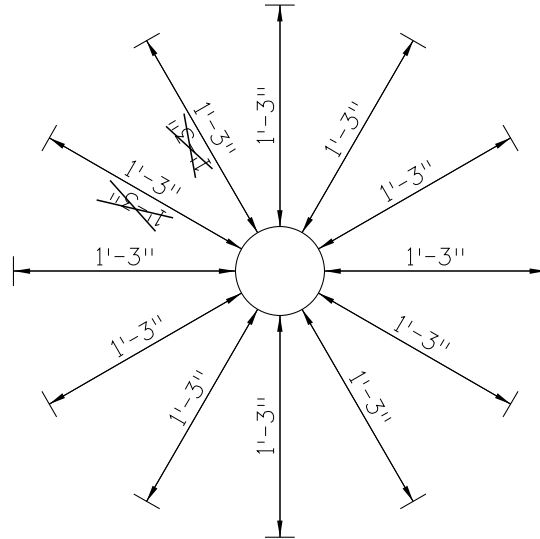

Fig. 2.7-3 Reading Directions for Dimensions

- E) Centerlines shall be shown and marked.
- F) Do not use a centerline as a dimension line. Centerlines may, however, be extended to serve as extension lines.
- G) Dimension lines are terminated with arrowheads which assist the eye in determining the extent of the dimensions. Arrowheads should be of a uniform size on a drawing. The width to length ratio of the arrowheads should be 1 to 3, see Figure 2.7-4. Arrows may be solid elements, although typical scales will generally show them as solid whether or not the element is solid.

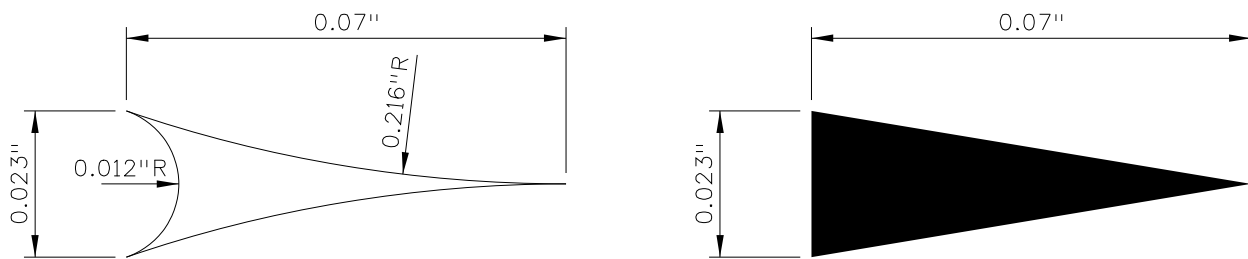

Fig. 2.7-4 Arrowheads

- H) Each dimension should be given clearly, so that it can be interpreted in only one way.
- I) Dimensions should not be duplicated or the same information be given in two different ways and no dimensions should be given except those needed to produce or inspect the part of the structure.
- J) Dimensions should be given between points or surfaces that have a functional relation to each other or that control the location of mating pieces.

- K) Dimensions should be shown in a way that will minimize calculation, preclude the need for scaling (measuring) from the hard copy, and assumption in the field.
- L) Dimensions should be placed in the views where the features dimensioned are shown in their true shape.
- M) Dimensions to hidden lines should be avoided wherever possible.
- N) Long extension lines should be avoided.
- O) Dimensions applying to two adjacent views should be placed between views, unless clarity is promoted by placing some of them outside.
- P) Longer dimensions should be placed outside intermediate dimensions so that dimension lines do not cross extension lines.
- Q) A dimension should be attached to only one view, not to extension lines connecting two views, e.g. plan and elevation views.
- R) The dimension lines of stringed detail dimensions should be aligned as shown in Fig. 2.7-5.

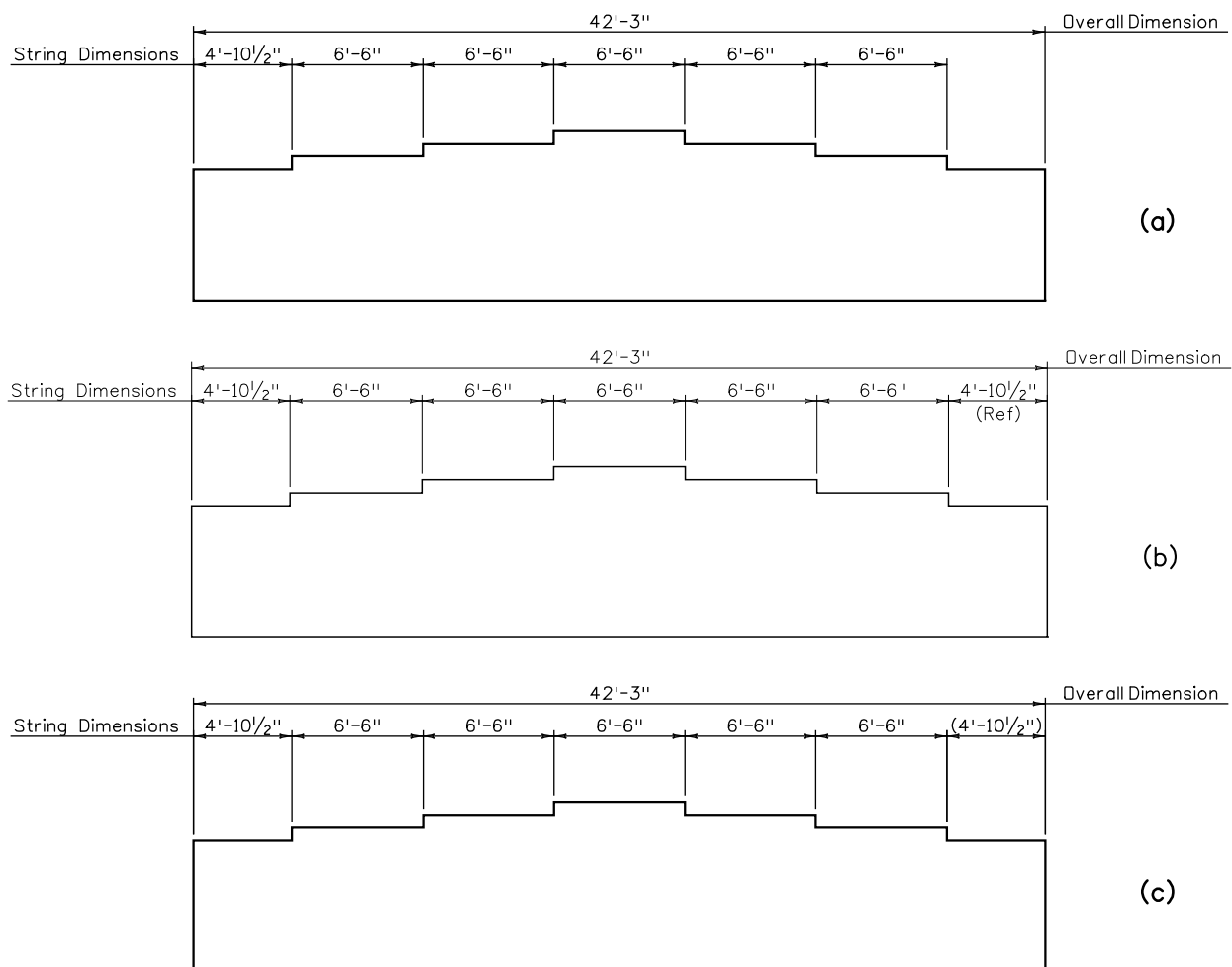

Fig. 2.7-5 String Dimensions

- S) String dimensions shall add up to the total overall dimension. A complete chain of detail dimensions should be avoided; it is better to omit one as shown in Figure 2.7-5 (a). If one is not omitted, REF (reference) should be added to the least critical of the string dimensions as shown in Figure 2.7-5 (b). Another acceptable option is to enclose the overall dimension or a particular

string dimension within parenthesis () as shown in Figure 2.7-5 (c) to show that a particular dimension may not be exact due to rounding errors.

- T) A dimension line should never be drawn through an object line. Text/lettering should not be placed on any lines of the drawing. The extension line can be broken if necessary. If possible, locate dimensions to avoid the situations. Otherwise break object lines or extension lines to clarify the dimensions.

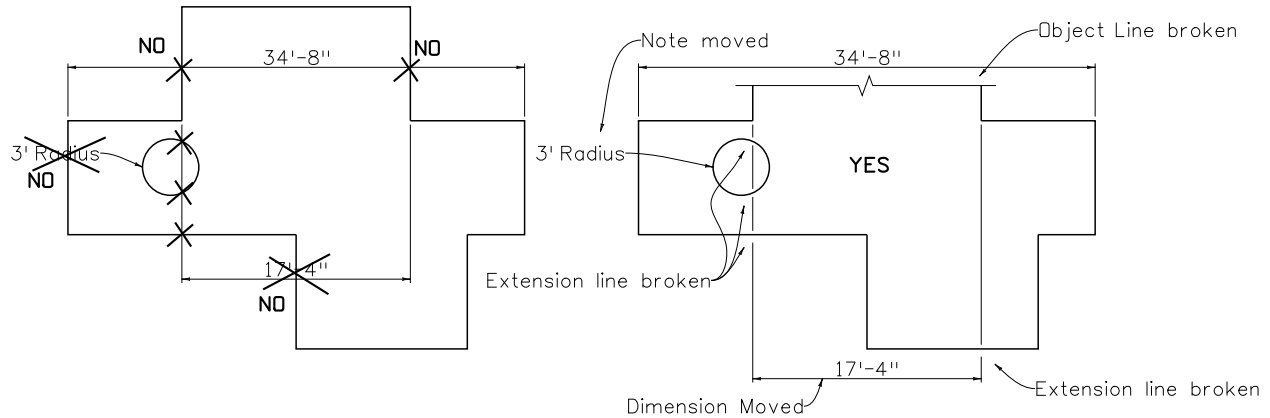

Fig. 2.7-6 Dimension and Object Lines

- U) Leader lines shall be either straight lines or smooth curves (continuous) terminated with arrowheads as shown in Figure 2.7-1.
- V) Some methods of showing compressed dimensions are shown in Figure 2.7-7. These techniques may be used in situations where the space is too tight for the numeral to fit between the extension lines.

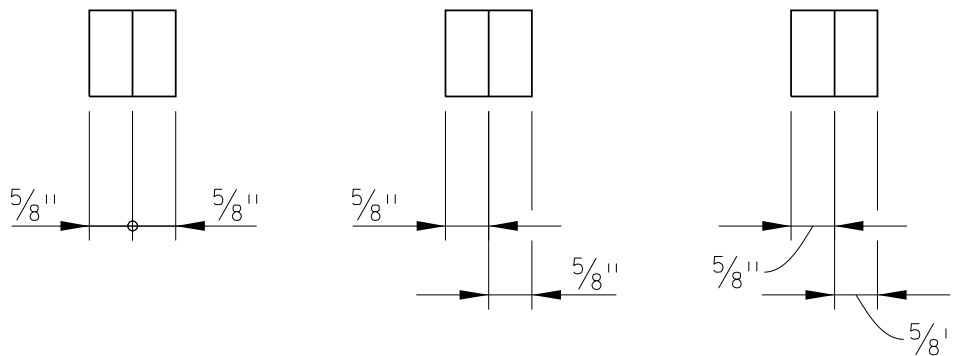

Fig. 2.7-7 Compressed Dimensions

- W) To indicate a dimension at a certain point on the structure, See examples in Figure 2.7-8. The small circles may be used to emphasize the extremities of the line being measured.

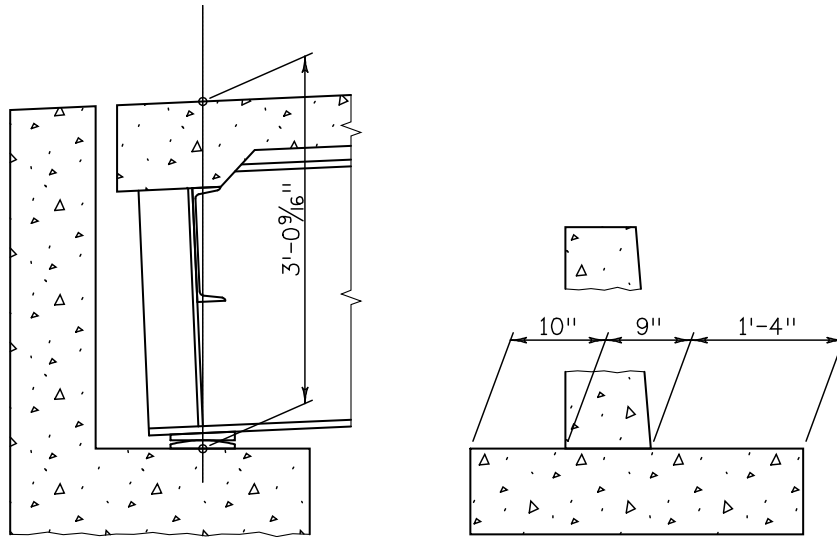

Fig. 2.7-8 Dimensioning to a Point

- X) Double arrowheads on a dimension line are used in partial views, in congested areas, or when it is not necessary to show the line to its termination. Figure 2.7-9 (a) shows a dimension line with two arrowheads at one end, indicating that the dimension line is not shown full length.

The limits of the dimension shall be noted on the line along with the magnitude. Similarly, the dimension line in Figure 2.7-9 (b) is not shown in its entirety, but indicates that in this example it is to extend 20'-4", in which distance there will be 21 #5 bars spaced at 1'-0"

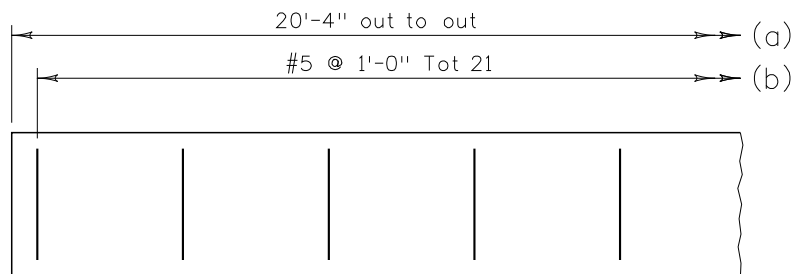

Fig. 2.7-9 Double Arrowheads

- Y) Various methods for showing angles are shown in Figure 2.7-10. For ease of reading, the text should remain horizontal.

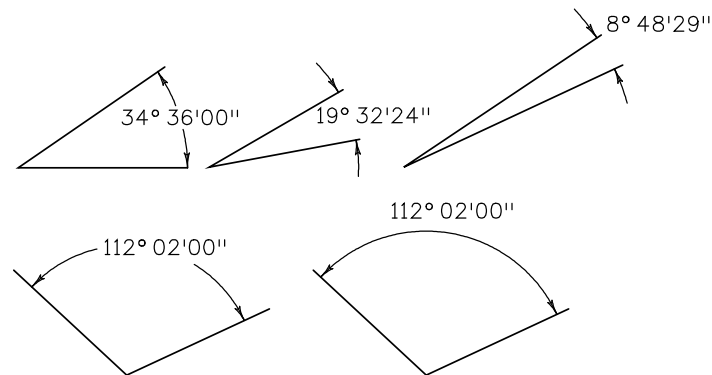

Fig. 2.7-10 Angles

- Z) Angles shall be dimensioned to tangents of the arc, not to the arc itself.

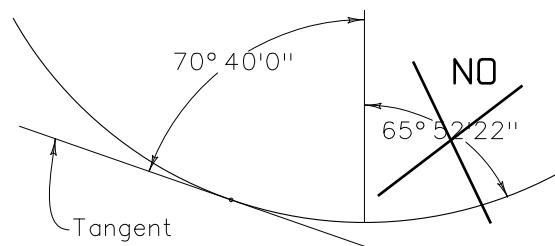

Fig. 2.7-11 Arc Tangents

- AA) Angles and bearings shall be given without hyphens as shown:

13° 21'

75° 00' 13"

N 18° 13' 00" E

S 41° 21' 14" W

Trailing zeros may be omitted when dimensioning angles. In electronic files this will need to be done by either manually editing the dimension text or modifying the dimension style:

OK: 13° 21' 00"

Preferred: 13° 21'

OK: 75° 00' 00" or 75° 00'

Preferred: 75°

BB) Radii may be shown as:

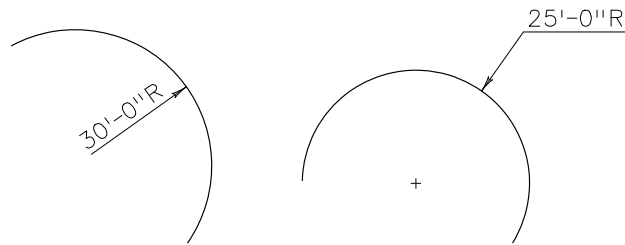

Fig 2.7-12 Radii

CC) Finish marks commonly found on bearing devices should be shown as:

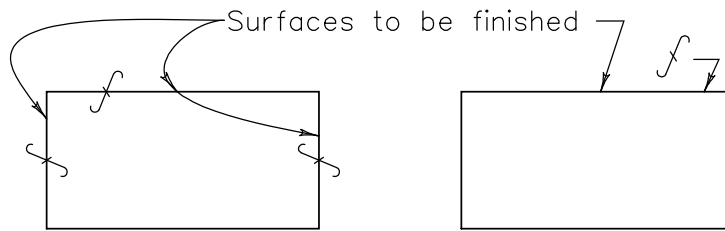

Fig. 2.7-13 Finish Marks

2.8 PATTERNS/HATCHING

To clarify the details and simplify the construction process, a number of patterns/hatching are used to represent certain materials. The more common patterns are shown in Figure 2.8-1. In a section view patterns/hatching should be used when it will help clarify the details and not create a cluttered appearance when the drawing is printed or copied. The amount of patterning/ hatching is left to the judgment of the detailer. The concrete hatch pattern should not be used when reinforcing is the subject of the detail.











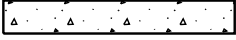

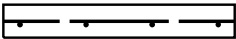
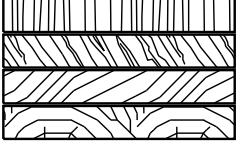
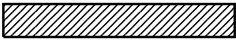
	Concrete
	Structural Steel
	Reinforced Concrete
	Timber
	Bronze
	Earth or Ground
	Fill or Sand
	Rock
	Riprap
	Grouted Riprap/Masonry
	Joint Filler
	Elastomeric Bearing Pad
	Hot Mix Asphalt (Bituminous Pavement)
	Brick
	Brick

Fig. 2.8-1 List of Common Patterns Used

2.9 ARCHITECTURAL TREATMENT

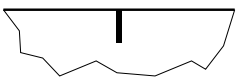
Architectural treatments, such as shades or shadows, regardless of their intended effect, should be used sparingly on structural drawings. If pictorial views with shades and/or shadows are required, they should be kept separate from the structural details.

2.10 DEFINITION OF BENT AND SKEW ANGLE

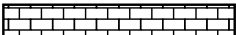
The bent angle is defined to be the acute angle measured between a longitudinal line (Layout or Girder Line) and a transverse line (Bent or Reference Line). The bent angle may be in any quadrant.

The skew angle is defined to be the acute angle measured between a reference line and a line perpendicular to the layout line. See Figure 2.10-1.

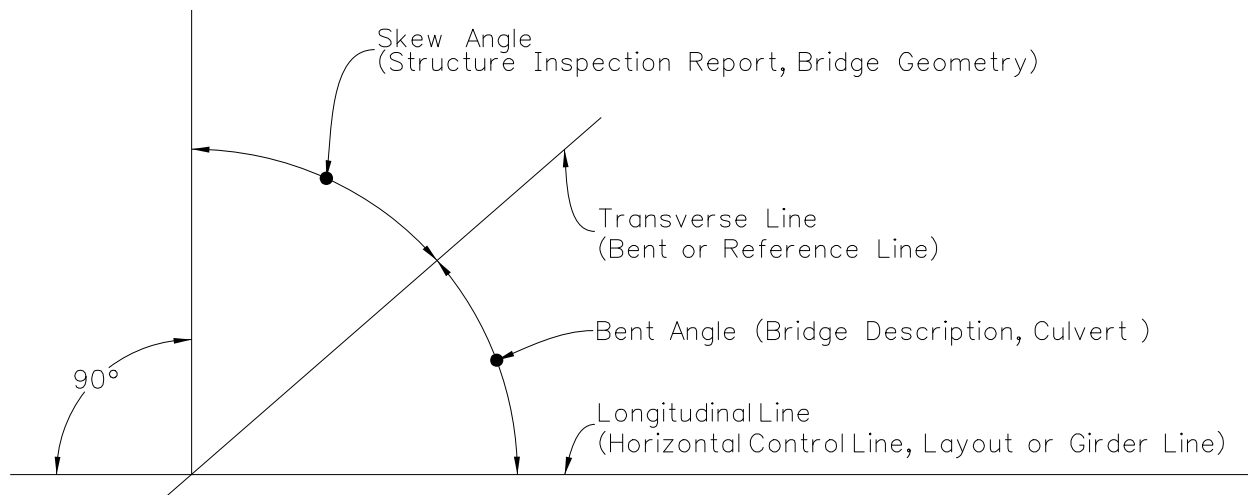

Fig. 2.10-1 Bent and Skew Angle

2.11 SECTION CUT LINE AND IDENTIFICATION

In Section 2.4, Figure 2.4-1 (Match Line, Section Line), the physical appearance of a section cut line is shown and described. This section describes its use and the characteristics of identification and location of the section.

Typically, sections are lettered and details are numbered.

The left portion of Figure 2.11-1 shows a partial plan view for a superstructure with concrete girders. A section "cut line" is shown extending through the plan. The arrowheads indicate the direction in which the section is being viewed. The circles that connect the arrows and the section "cut line" contain the section identification and the drawing number where the section can be found. If the drawing number is blank or a dash, the reference is found on the same drawing. A final drawing should not contain a sheet reference that contains the "B" prefix with no accompanying drawing number. An identification letter is placed in the upper half of the circle. In Figure 2.11-1, the drawing number is B7, the section cut is identified as "A", and the B10 in the circle indicates that the section is detailed on Drawing Number B10. If the section had been detailed on Drawing Number B7 where it was cut, the drawing number in the circle would be a dash or left blank.

The right portion of Figure 2.11-1, shows a detail of Section A, which is on Drawing Number B10. The circle in the title shows that it is Section "A", and B7 refers to Drawing Number B7, on which the cut line for Section "A" will be found. Bubble references are recommended on both sides of a section cut when the section markers are far away from each other and an arrow reference can be lost amongst the linework and text.

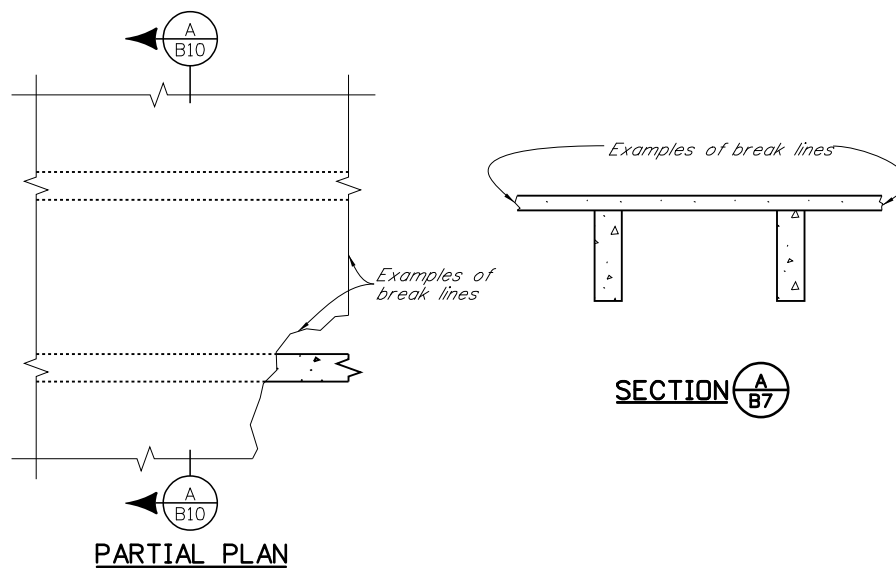

Fig. 2.11-1 Section Cut Example

Figure 2.11-2 shows an enlarged detail of a typical identification circle and arrow for a section cut line.

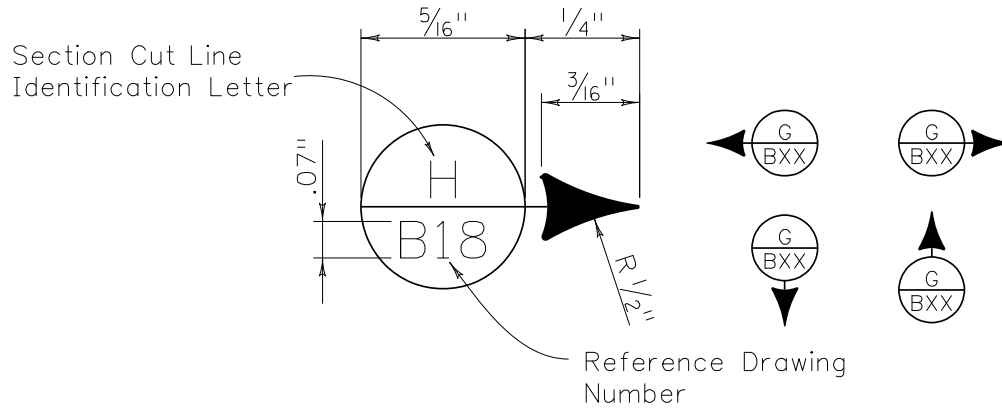

Fig. 2.11-2 Typical Section Arrow and Identification Circle

Figure 2.11-3 shows typical references in titles. A common section may be used for multiple sheets and the title would reflect the sheets that are referenced as shown in the right of Fig 2.11-3



Fig. 2.11-3 Typical Section Titles

The practice of having the Identification Letter on top is opposite of past practice at CDOT, but is consistent with industry standard. Both practices are acceptable as long as the drawing set is consistent and clear. The practice as shown above is preferred.

Figure 2.11-4 shows details of typical identification circle and arrow for identifying location and direction of isometric views or photographs and title examples.

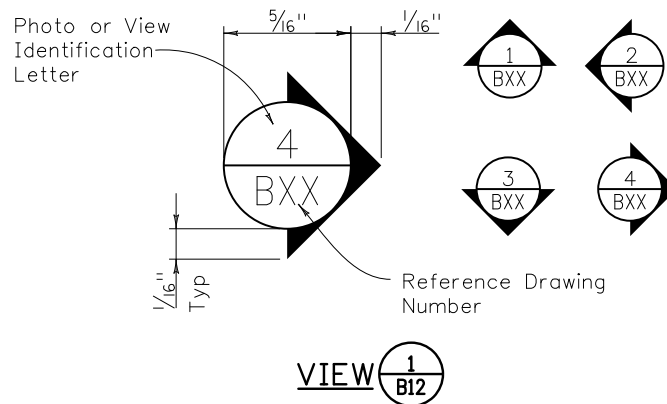

Fig. 2.11-4 Typical View Indicators

2.12 DETAIL IDENTIFICATION

Sometimes, for the sake of clarity, it is advisable to make an enlarged detail of a certain area in a view. Figure 2.12-1 shows an example. A circle is made to a diameter large enough to encompass the area that is to be shown in the enlarged detail. Inset in the line of this circle is an identification circle the same size as the identification circles used for the section cuts. The notation for the circle shall follow the same rules as for the identification circles used for section cuts. If the view and the enlarged detail are near together, they may be connected with a short leader line and the identification circles and detail title omitted. Typically, details are numbered and sections are lettered.

Figure 2.12-1 shows the enlarged detail "2", with the proper identification circle in the title.

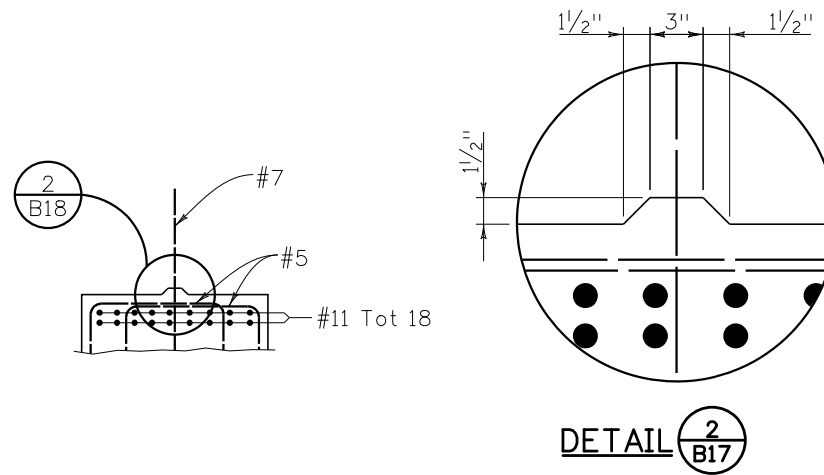

Fig 2.12-1 Enlarged Detail

2.13 STANDARD ABBREVIATIONS

- A) Abbreviations shall never be used when the meaning may be in doubt.
- B) Abbreviations should be avoided in titles, subtitles, and notes.
- C) Acceptable abbreviations are shown in the M&S Standards. Appendix A contains historically used abbreviations.

2.14 ARROWS

North Arrows are placed to aid in the orientation of the drawings to the structure location. Acceptable North arrows are shown in Figure 2.14-1.

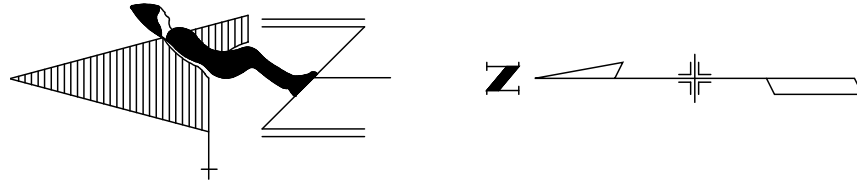

Fig. 2.14-1 Acceptable North Arrows

Directional Arrow for Water Flow. Any plan showing flow of water shall have an arrow indicating direction of flow. Figure 2.14-2 shows the arrows to be used in such cases.

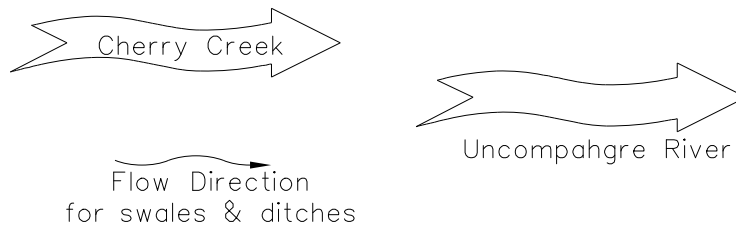
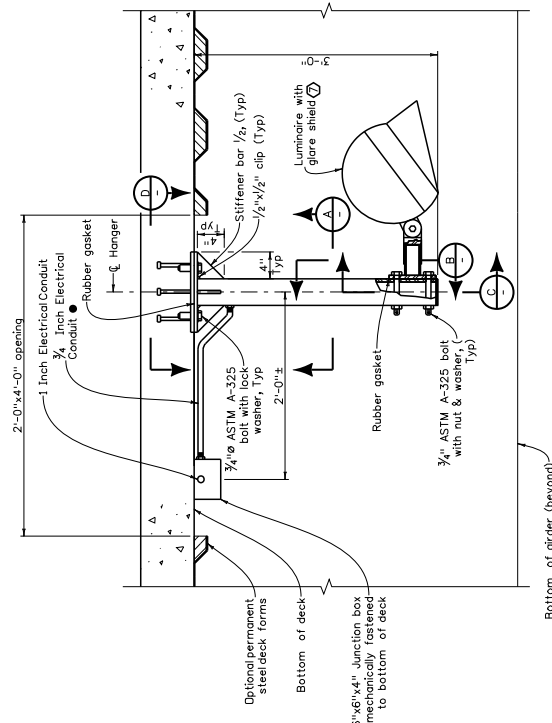
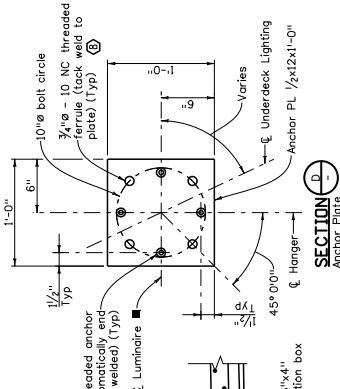
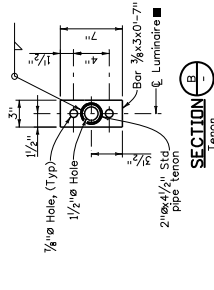
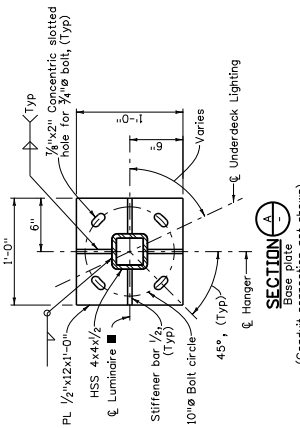
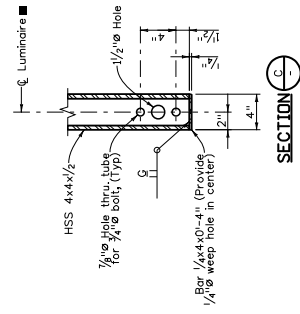

Fig. 2.14-2 Flow Arrows

2.15 NOTES

Notes that are applicable to the entire structural set shall be included with the General Notes on the first sheet of the set. Notes that are sheet or item specific should be included on the appropriate sheets, i.e. notes specific to abutments should be on the abutments sheets. When there is insufficient room for a detailing note, symbols or numbered symbols may be used to place the note where there is sufficient space. The symbol legend, Note Key or Keyed Notes should be located in the lower right portion of the drawing for consistency purposes. Separate lists of keyed notes are not necessary and numbered symbols may reference notes on the sheet. In addition to insufficient space, multiple references to a note may be justification for their use. In general, the use of symbols and keyed notes should be avoided when possible.



LUMINAIRE HANGER DETAIL

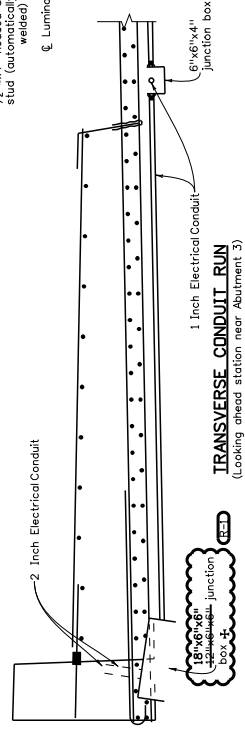

TRANSVERSE CONDUIT RUN
(Looking ahead station near Abutment 3)

- NOTES**
1. Cost of providing and installing luminaire hanger shall be included in the cost of the luminaire. See Lighting Plans.
 2. Hanger assembly shall be ASTM A-36.
 3. If permanent steeldeck forms are used, provide 2'-0"x4'-0" opening in steel forms and form zone around hanger with removable forms. Center opening to include hanger and junction box.
 4. Following fabrication, all steel components shall be galvanized, in accordance with Section 509.
 5. Use rubber gasket between all steel-to-steel connections.
 6. For underdeck luminaire locations and additional notes, see "Construction Layout" sheet.
- ⑦ Attach luminaire to tenon per Manufacturer's recommendations. For luminaire details, see Lighting Plans.
 - ⑧ Provide 7/8" hole through Anchor Plate at each ferrule location.
 - Provide connection in tube and junction box for 3/4" electrical conduit.
 - Luminaire shall be parallel to Girders and shall be approximately centered between girders.
 - + Locate junction box to clear reinforcing. Up to one bottom mat bar in each direction may be cut to clear junction box.

Fig. 2.15-1 Example of Preferred Notes